

Rev. 0001	Date of issue xx/xx/xxxx	Description First edition	Sign x.x.
--------------	-----------------------------	------------------------------	--------------

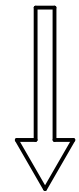
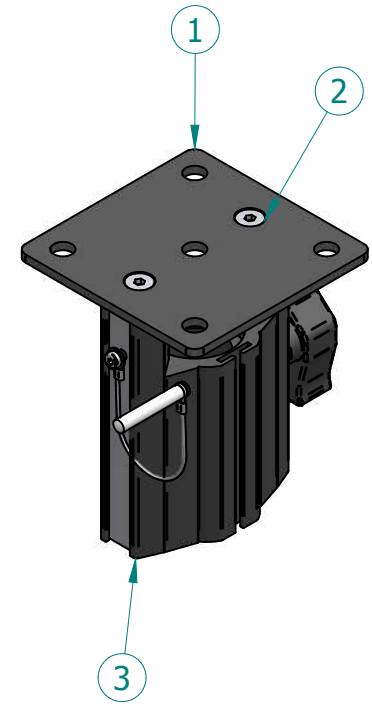
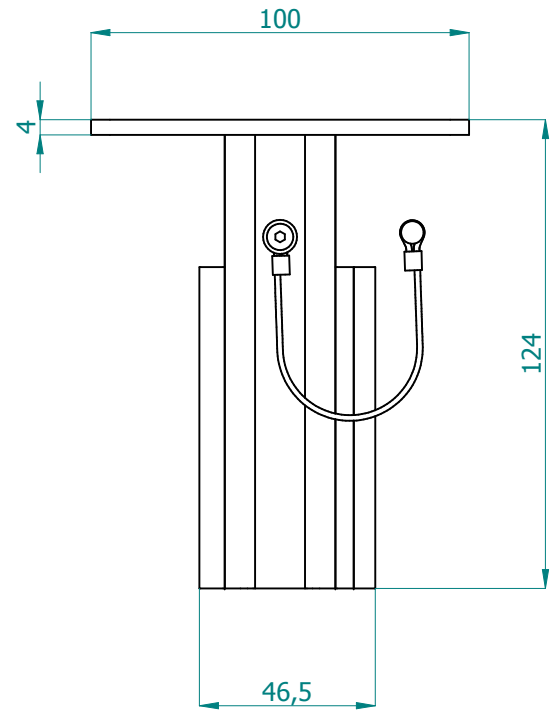
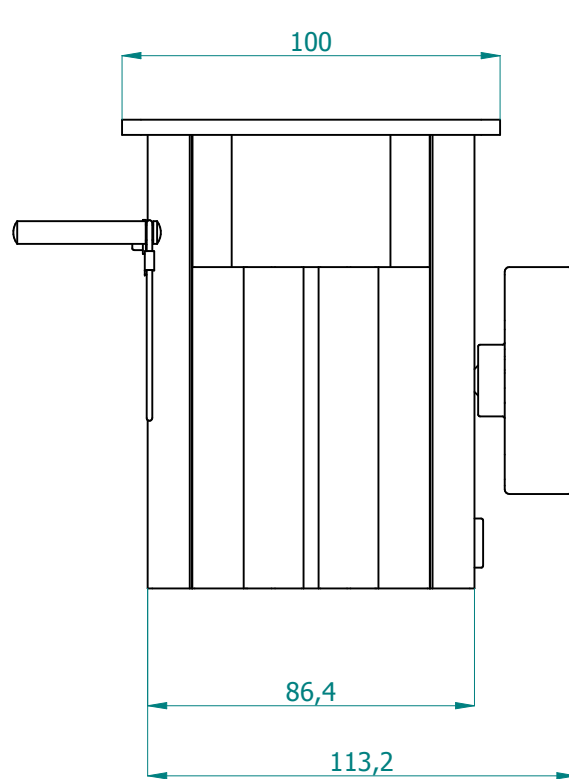

WLL 60kg

Pos.	Code	Description	Q.ty
1	X3620,02	Staffa per bloccaggio	1
2	VU5933-06X30	UNI 5933 Vite M6x30 TSPEI	2
3	BU-001	Bushing 28 mm.	1

<b>UNIRIG</b> STAGING & RIGGING		Material		Treatment/Finishing	
Chamfers not indicated 0,5x45°		Roughness Ra 3,2		General tolerances For linear dimensions: ±0,1 mm For angular dimensions: ISO 2768-m	
UNIRIG srl, via F.lli Lumière, 15 - 47122- La Selva - Forlì - Italy TEL. +39 0543 783511 FAX +39 0543 783550 www.unirig.it info@unirig.it		Created by <b>Marco</b>		Checked by -	
Title/Supplementary title Staffa Bushing 1"1/8		Date of issue <b>14/06/2016</b>		Weight [kg] <b>0,96 kg</b>	
Code name/File name <b>RA869</b>		Project		Scale <b>1:2</b>	
Paper size A4		Sheet <b>1\1</b>		Approved by -	

This drawing is copyright and the property of UNIRIG. It must not be copied (in whole or in part) used for manufacture, or otherwise disclosed without written consent of the company.